

ProMinent Electronic Dosing Pumps

ProMinent Electronic Dosing Pumps Type Concept CC3 and B are available in 16 models and up to a capacity of 60 l/hr.

The ProMinent Electronic Dosing Pumps are solenoid driven and controlled electronically by a PCB. The only moving part in the Pump is the solenoid armature which has a maximum movement of 1.25mm only and therefore the Pump is virtually maintenance free.

The Developan diaphragm of the Pump is made of high quality fabric reinforced EPDM with moulded in steel core and coating of teflon on the media contacted side.

The Housings of the Concept CC3 Pumps are made of Noryl plastic and for the B Pumps the housings are made of die-cast Aluminium with chemical resistant coating.

The Concept CC3 and B Pumps have the optional facility for accepting pulse or 0/4-20mA signals for automatic control of dosing. These Pumps also have the in built feature for low level indication in the Dosing Tank through a tank level switch.



ProMinent CC3



Double ball valves on the suction and discharge side ensure maximum accuracy.

The liquid ends of the Concept CC3 and B Pumps can be offered in Acrylic (N), PVC (P), Polypropylene (PP), Teflon (T) or Stainless Steel (S).

The Pumps are suitable for a supply of 230V, 50 c/s, single phase.

To select a suitable Pump the following information is required

■ Chemical to be dosed
■ Capacity in litres/hour
■ Back pressure

ProMinent Electronic Dosing Pumps offer high technology based and proven solutions to any dosing requirement.

TECHNICAL DATA

ProMinent Electronic	Ratings at Max. back pressure		Ratings at Nominal back pressure		Max. frequency (strokes / hour)	Nominal Power (Watt)	Connection Size (O.D. x ID mm)	Suction lift (mWC)	Shipping weight kg.
	bar	l / h	bar	l / h					
CC3 1000	10	0.156	6	0.168	5625	12	6 x 4	1.5	2.5
CC3 1601	16	0.70	8	0.91	5625	12	6 x 4	6	2.5
CC3 1201	12	1.21	6	1.41	5625	12	6 x 4	6	2.5
CC3 0703	7	2.66	4	3.12	5625	12	6 x 4	3	2.5
CC3 1002	10	1.63	5	2.19	5625	12	8 x 5	6	2.7
CC3 0407	3.5	6.3	2	6.42	5625	12	8 x 5	6	2.7
CC3 0212	1.5	11.5	1	12.40	5625	12	8 x 5	1.5	2.9
B 20.001*	20	1.44	10	1.87	7200	54	8 x 5	6	6
B 20.005*	20	4.22	10	4.81	6600	117	8 x 5	6	11
B 10.006	10	5.76	6	6.4	7200	54	8 x 5	5	6
B 13.010*	13	9.9	6	10.82	6600	117	8 x 5	6	11
B 06.012	6	11.93	3	13.25	7200	54	8 x 5	3	6
B 08.013	8	12.95	4	15.05	6600	117	12 x 9	5	11
B 04.017	3.5	16.71	2	18.36	7200	54	12 x 9	2.5	6
B 04.23	3.5	24.0	2	24.6	6600	117	12 x 9	2	12
B 02.35	1.25	34.92	1	36.0	7200	54	12 x 9	1.5	6
B 02.055	1.5	54.6	1	60.0	6600	117	DN 15	1	12

* These models are available with liquid ends of Acrylic and Stainless Steel only.

The shipping weight is given for Pumps with liquid ends of N, P, PP and T. It will be slightly higher for pumps with liquid ends of S.

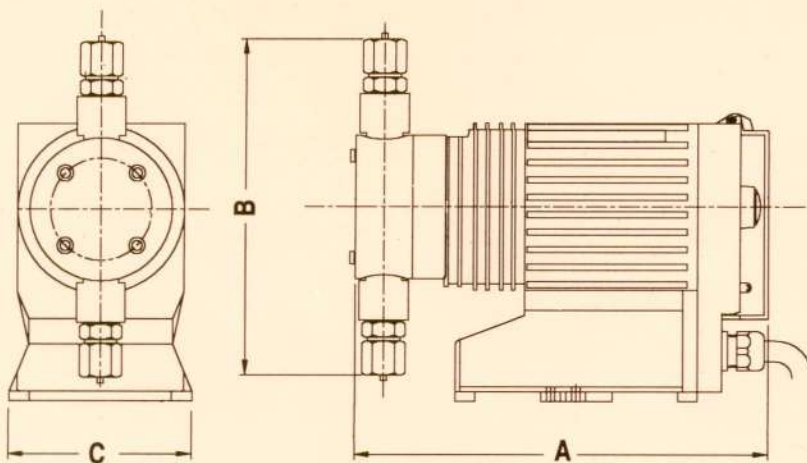

DIMENSIONS

Model	A	B	C
CC3	200	198	90
B	260	260	136

Heidelberg ProMinent Fluid Controls India Pvt. Ltd. is a fully owned subsidiary of ProMinent Dosiertechnik GmbH, Germany.

For further details please contact :

Heidelberg ProMinent Fluid Controls India Pvt. Ltd.,

(Fully Owned Subsidiary of ProMinent Dosiertechnik GmbH, Germany)

2/2, MES Road, Yeshwanthpur, Bangalore - 560 022

Tel: 00 91 80 23578872 / 73 / 74, 23370730, 23374954 Fax: 00 91 80 23477984, 23573743

E-mail : prominent@hpfcindia.com Website: www.prominentindia.com